



22<sup>nd</sup> February 2017

Mr. David Wright  
Vehicle Programs and Compliance Division  
Environmental Protection Agency  
2000 Traverwood,  
Ann Arbor, MI 48105

**Subject: Request for issuance of a new certificate of Conformity – Running change to add Model S 100D and New 75 kWh FW limited battery pack configuration**

Tesla, Inc. requests that the EPA issue a Certificate of Conformity for the subject test group. Attached to this request is the Part 1 Application. Tesla believes that the test group complies with all applicable regulations contained within Title 40 of the CFR, California Amendments to Subparts B, C, and S, Part 86 and Part 88, Title 40 of the CFR and Title 13 of the California Code of Regulations

|                                       |  |
|---------------------------------------|--|
| Vehicle Category:                     | Light Duty Vehicle (< 8000 lbs. GVW)   |
| Durability Group:                     | HTSLEEVNNL2S   |
| Test Group:                           | HTSLV00.0L2S   |
| Summary Sheet No:                     | NA   |
| Durability Group Description:         | NA   |
| Durability Vehicle:                   | NA   |
| OBD Group:                            | NA   |
| Test Group Description:               | Tesla differentiates test groups based on: 1) battery type, 2) number of drive motors, and 3) vehicle line.<br><br>L- Lithium Ion Battery<br>2 – Dual AC induction motors –base version (front / rear) & performance version (rear only)<br>S – Model S AWD Line of vehicles |
| Applicable Standards:                 | FEDERAL Tier 3 BIN 0 & CALIFORNIA ZEV  |
| Carlines Covered by this certificate: | 60D, 75D, 90D, P90D, P100D, 100D   |

Your early review and issuance of the certificate will be greatly appreciated. If you have any questions, please contact me at our office at (510) 249-8749

Sincerely,

Director – Vehicle Homologation,  
3500 Deer Creek Road, Palo Alto, CA 94304, ph 650-681-5000 fax 650-681-5200

## Contents

|              |  |
|--------------|--|
| <b>01.00</b> | <b>Communications</b>  |
| 01.01        | Mailing information  |
| 01.01.01     | Certification information  |
| 01.01.02     | Responsible official   |
| <b>03.00</b> | <b>Facilities, Equipment and Test Procedures</b>                                 |
| 03.01        | Procedure to determine mass emissions of the fuel fired heater                   |
| 03.02        | Battery pre-conditioning procedures  |
| 03.03        | Vehicle Configuration and sub-configurations                                     |
| 03.04        | Test Procedures  |
| <b>04.00</b> | <b>Statement of Compliance</b>   |
| <b>05.00</b> | <b>Reserved</b>  |
| <b>06.00</b> | <b>Maintenance</b>   |
| 06.01        | Test vehicle scheduled maintenance   |
| 06.02        | recommended customer maintenance schedule  |
| 06.03        | Lubricants and heater fuels  |
| <b>07.00</b> | <b>Labels</b>  |
| 07.01        | Label locations  |
| 07.02        | Sample emission control information label  |
| 07.03        | California Environmental Performance Index label: 2015<br>and later model years  |
| 07.04        | Projected sales information  |
| <b>08.00</b> | <b>General Technical Description</b>   |
| 08.01        | Description of propulsion system   |
| 08.02        | Description of motor(s)  |
| 08.03        | Description of batteries   |
| 08.03.01     | Battery charging capacity  |
| 08.03.02     | Self-discharge information   |
| 08.03.03     | Description of thermal management system   |
| 08.03.04     | Definition of end-of-life  |
| 08.03.05     | Description of battery disposal plan   |
| 08.04        | Description of controller / inverter   |
| 08.05        | Description of transmission  |
| 08.06        | Description of climate control system  |
| 08.06.01     | Electric heat pump   |
| 08.06.02     | Fuel-fired heater  |
| 08.06.03     | Climate control system logic   |
| 08.06.04     | Tamper resistance of climate control system that<br>includes a fuel-fired heater |
| 08.07        | Description of regenerative braking system                                       |
| 08.07.01     | Control logic  |
| 08.07.02     | Percentage of braking performed on road by each axle                             |
| 08.08        | Description of charger   |
| 08.08.01     | Proper recharging procedures   |
| 08.08.02     | Power requirements necessary to recharge vehicle                                 |
| 08.09        | Accessories which draw energy from the batteries                                 |
| 08.10        | Other unique features (solar panels)   |
| 08.11        | Description of warning system(s) for maintenance / malfunction                   |
| 08.11.01     | Cut-off terminal voltages for prevention of battery damage                       |

|              |   |
|--------------|---|
| <b>09.00</b> | <b>Running Change vehicle description</b>   |
| <b>10.00</b> | <b>Road load data</b>   |
| <b>11.00</b> | <b>Starting and shifting schedules</b>  |
| 11.01        | Starting  |
| 11.02        | Shifting  |
| <b>12.00</b> | <b>Reserved</b>   |
| <b>13.00</b> | <b>Reserved</b>   |
| <b>14.00</b> | <b>Reserved</b>   |
| <b>15.00</b> | <b>Reserved</b>   |
| <b>16.00</b> | <b>Reserved</b>   |
| <b>17.00</b> | <b>California Requirements</b>  |
| 17.01        | Statement of compliance   |
| 17.01.01     | General statement   |
| 17.01.02     | Driveability statement  |
| 17.02        | Supplemental data and certification review sheets   |
| 17.03        | Engineering evaluation of zero evaporative emissions under any and all operating conditions (for vehicles equipped with fuel-fired heater only) |
| 17.04        | Credits   |
| 17.04.01     | Description of multi-manufacturer agreements  |
| 17.04.02     | Credit calculation  |
| 17.05        | Vehicle safety  |
| 17.05.01     | All information on safe handling of vehicle   |
| 17.05.02     | Information on safe handling of battery system  |
| 17.05.03     | Description of emergency procedures   |
| 17.06        | Description of fuel-fired heater / fuel tank evaporative system   |
| <b>18.00</b> | <b>Fuel Economy Data Vehicle and De-Rating calculations</b>   |

**01.00 COMMUNICATIONS**

01.01 ***Mailing information***

01.01.01 ***Certification information***

Tesla, Inc  
3500 Deer Creek Road  
Palo Alto, CA 94304

01.01.02 ***Responsible officials***

02 Mr Suraj Nagaraj (Primary Contact)  
Director- Vehicle Homologation  
03 Telephone 510 249 8749

**03.00 FACILITIES, EQUIPMENT AND TEST PROCEDURES**

Internal range test reports are on file at Tesla

03.01 ***Procedure to determine mass emissions of the fuel-fired heater***

Not applicable; vehicle not equipped with a fuel fired heater.

03.02 ***Battery pre-conditioning procedures***

The lithium ion battery cells are cycled by the battery cell manufacturer before they are assembled into battery packs.  
There is no further pre-conditioning necessary.

**Vehicle Configurations and sub configurations**

|  |                                     |                                     |                                     |                                     |                                     |                                     |
|--|-------------------------------------|-------------------------------------|-------------------------------------|-------------------------------------|-------------------------------------|-------------------------------------|
| <b>Make</b>  | Tesla                               |                                     |                                     |                                     |                                     |                                     |
| <b>Carline</b>   | Model S AWD                         |                                     |                                     |                                     |                                     |                                     |
| <b>Type</b>  | Battery Electric Vehicle            |                                     |                                     |                                     |                                     |                                     |
| <b>Test Group</b>  | HTSLV00.0L2S                        |                                     |                                     |                                     |                                     |                                     |
| <b>Final Drive ratio</b>                                     | 9.73                                |                                     |                                     |                                     |                                     |                                     |
| <b>Emission Control</b>                                      | NA (BEV)                            |                                     |                                     |                                     |                                     |                                     |
| <b>Exhaust</b>   | NA (BEV)                            |                                     |                                     |                                     |                                     |                                     |
| <b>Evap</b>  | NA (BEV)                            |                                     |                                     |                                     |                                     |                                     |
| <b>Model Type</b>  | <b>60D</b>                          | <b>75D</b>                          | <b>90D</b>                          | <b>100D</b>                         | <b>P90D</b>                         | <b>P100D</b>                        |
| <b>Basic Engine code (F/R)</b>                               | L2S/L2S                             | L2S/L2S                             | L2S/L2S                             | L2S/L2S                             | L2S/L1S                             | L2S/L1S                             |
| <b>Transmission Type / Code</b>                              | AV/1                                | AV/1                                | AV/1                                | AV/1                                | AV/1                                | AV/1                                |
| <b>Vehicle ID tested</b>                                     | DS116-L2S                           | DS216-L2S                           | DS316-L2S                           | DS417-17225                         | DP316-L2S                           | DP416-L2S                           |
| <b>Configuration #</b>                                       | 0                                   | 0                                   | 0                                   | 0                                   | 0                                   | 0                                   |
| <b>Sub configuration #</b>                                   | 0                                   | 0                                   | 0                                   | 0                                   | 0                                   | 0                                   |
| Min Curb Mass (lbs)  | 4723                                | 4723                                | 4789                                | 4873                                | 4840                                | 4939                                |
| Gross Vehicle Weight (lbs)                                   | 5820                                | 5820                                | 5808                                | 5926                                | 5874                                | 6043                                |
| Equivalent Test Weight (ETW) (lbs)                           | 5000                                | 5000                                | 5000                                | 5250                                | 5250                                | 5250                                |
| Base wheel / Tire (F&R)                                      | 245/45R19                           | 245/45R19                           | 245/45R19                           | 245/45R19                           | 245/45R19                           | 245/45R19                           |
| <b>Target Road Load<br/>A (N)<br/>B N/kph<br/>C (N/kph2)</b> | a=37.37,<br>b=0.1842,<br>c= 0.01508 | a=37.37,<br>b=0.1842,<br>c= 0.01508 | a=39.24,<br>b=0.1493,<br>c= 0.01514 | a=40.52,<br>b=0.1677,<br>c= 0.01614 | a=41.51,<br>b=0.2226,<br>c= 0.01403 | a=41.35,<br>b=0.2670,<br>c= 0.01370 |
| RLHP @ 50mph   | 11.24                               | 11.24                               | 11.27                               | 11.9                                | 11.7                                | 12.44                               |
| <b>Sub configuration #</b>                                   | 1                                   | 1                                   | 1                                   | 1                                   | 1                                   | 1                                   |
| Min Curb Mass (lbs)  | 4723                                | 4723                                | 4789                                | 4873                                | 4840                                | 4939                                |
| Gross Vehicle Weight (lbs)                                   | 5820                                | 5820                                | 5808                                | 5926                                | 5874                                | 6043                                |
| Equivalent Test Weight (ETW) (lbs)                           | 5000                                | 5000                                | 5000                                | 5250                                | 5250                                | 5250                                |
| <b>Target Road Load<br/>A (N)<br/>B N/kph<br/>C (N/kph2)</b> | a=63.27<br>b=0.2213,<br>c= 0.01748  | a=63.27<br>b=0.2213,<br>c= 0.01748  | a=65.14<br>b=0.1493,<br>c= 0.01514  | a=44.06<br>b=0.1851,<br>c= 0.01747  | a=46.81<br>b= 0.1601<br>c = 0.01623 | a=46.65,<br>b=0.2670,<br>c= 0.0159  |
| Wheel / Tire   | 245/35R21                           | 245/35R21                           | 245/35R21                           | 245/35R21                           | 245/35R21                           | 245/35R21                           |
| Road Load HP @ 50mph   | 12.57                               | 12.57                               | 12.6                                | 12.93                               | 12.31                               | 13.05                               |

Fuel Economy Data Vehicle (FEDV) Selection Justification – FEDV curb mass vehicle accounts for options that have a greater than 33% take rate and highest sold wheel/tire combination that collectively represents a vehicle configuration / sub configuration that has the largest sales volume within that Model Type. Tesla affirms that the road load power, and the target coefficients are those that are appropriate for the ETW of the vehicle.

### 03.04 Test Procedures

SAE J1634 (as revised 2012-10) was followed for all Range testing and SAE J2263 (as issued 1996-10) was followed for Road load measurement.

#### **SPECIAL TEST INSTRUCTIONS**

This vehicle shall only be tested on a 4 wheel dyno.

##### Vehicle Settings

- Battery stabilized on the vehicle for 1000 miles.
- Vehicle charged to 100% SOC
- Dyno Mode ON – This setting prevents TC faults.
- Regen – Standard
- Climate OFF
- Headlights OFF
- Creep Mode OFF
- Screen brightness set to default (50%)
- Radio OFF

##### Instrumentation

- Battery voltage and Current measurement – Hioki 3390-10
- AC recharge – Hioki 3390-10

##### Lock car upon exit



Rear: soft straps to rear sub frame

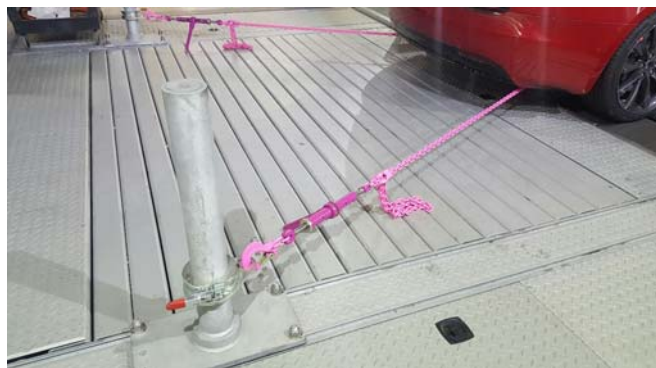

#### 04.00 Statement of Compliance

This vehicle conforms to US EPA Federal Tier 3 Bin 0 and State of California regulations applicable to 2017 Model Year new ZEV Light-duty Vehicles

**05.00 RESERVED**

**06.00 MAINTENANCE**

06.01 ***Test vehicle scheduled maintenance***

Not applicable.

06.02 ***Recommended customer maintenance schedule***

See Owner Hand Book.

06.03 ***Lubricants and heater fuels***

Heater fuel: Not applicable

Transmission lubricant: ***Factory Fill***

Capacity: 1.325 litres

Make: Exxon Mobile

Trade name: Dexron VI

Type: Mineral oil

Viscosity: 11,500 cP at -40°C (-40°F)

5.8 cSt at 100°C (212°F)

***Test Vehicle***

Same as factory fill

07.00

**LABELS**

07.01

**Label locations**

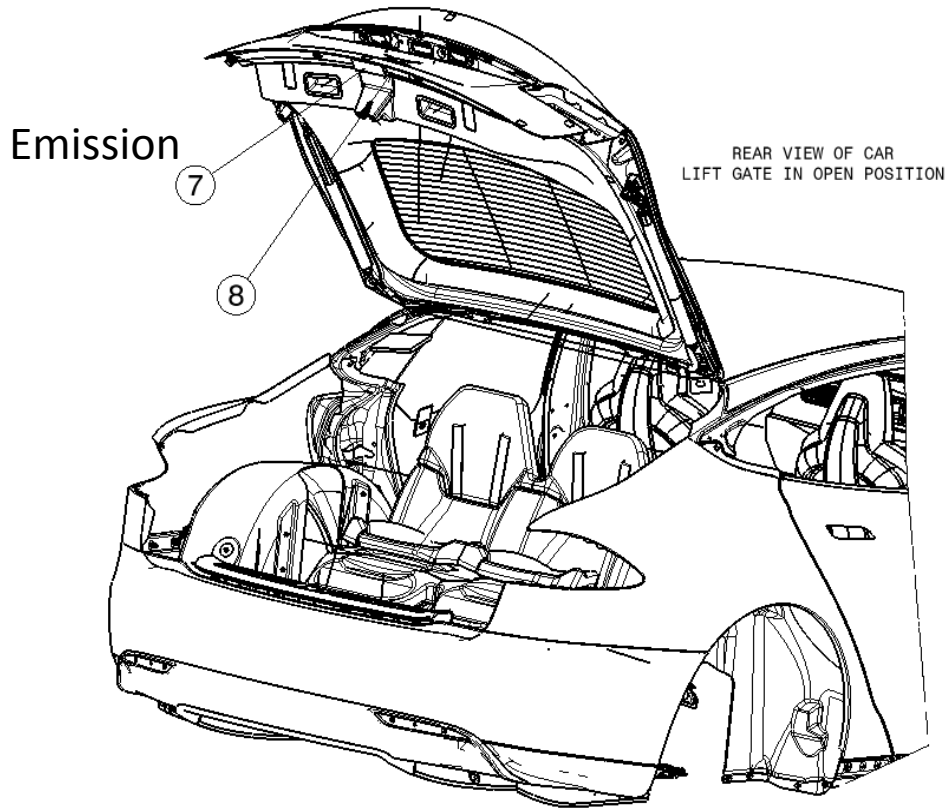

See 07.02

Monroney label

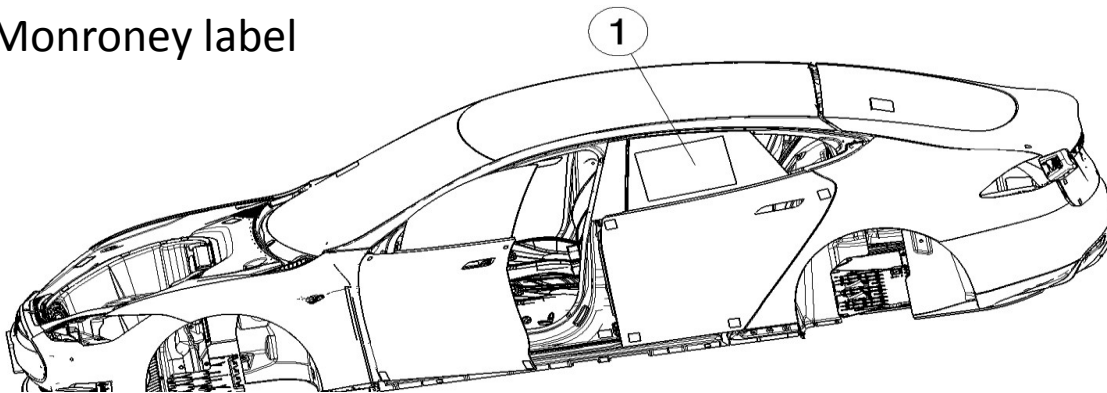

See 07.03

07.02

**Emission Control Information label: 2017 Model Year**

(Mandated in CFR Title 40, Part 86; §86.1807. Label format agreed with EPA)



07.03

**California Environmental Performance Index label: 2017 Model Year**

(Mandated in California Environmental Performance Label Specifications for 2009 and Subsequent Model Passenger Cars, Light-Duty Trucks and Medium-Duty Passenger Cars. Label format agreed with EPA/ CARB)

**P90D**

**P90D**

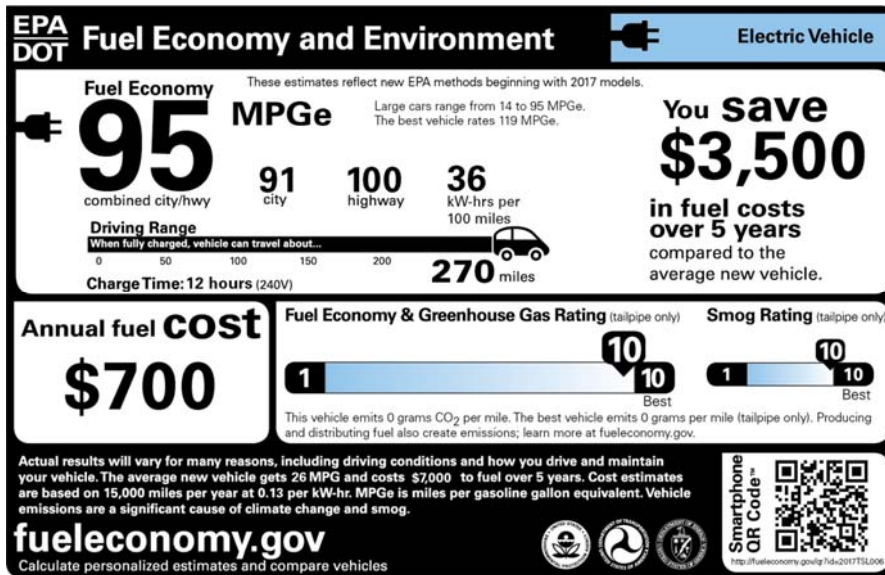

**90D**

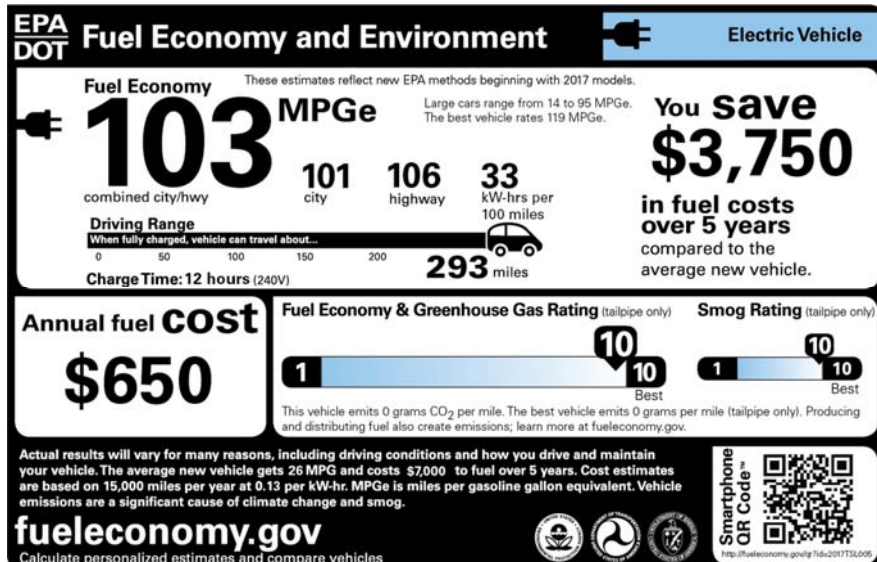

75D

**EPA DOT**

**Fuel Economy and Environment**

**Electric Vehicle**

These estimates reflect new EPA methods beginning with 2017 models. Large cars range from 14 to 95 MPGe. The best vehicle rates 119 MPGe.

**Fuel Economy**

**103** MPGe

combined city/hwy

102 city    105 highway    33 kW-hrs per 100 miles

**Driving Range**

When fully charged, vehicle can travel about...

Charge Time: 12 hours (240V)

**You save**

**\$3,750**

**in fuel costs over 5 years**

compared to the average new vehicle.

**Annual fuel cost**

**\$650**

**Fuel Economy & Greenhouse Gas Rating** (tailpipe only)

**Smog Rating** (tailpipe only)

This vehicle emits 0 grams CO<sub>2</sub> per mile. The best vehicle emits 0 grams per mile (tailpipe only). Producing and distributing fuel also create emissions; learn more at fueleconomy.gov.

Actual results will vary for many reasons, including driving conditions and how you drive and maintain your vehicle. The average new vehicle gets 26 MPG and costs \$7,000 to fuel over 5 years. Cost estimates are based on 15,000 miles per year at 0.13 per kW-hr. MPGe is miles per gasoline gallon equivalent. Vehicle emissions are a significant cause of climate change and smog.

**fueleconomy.gov**

Calculate personalized estimates and compare vehicles

Smartphone QR Code™

<http://fueleconomy.gov/g/75d2017TSL004>

60D

**EPA DOT**

**Fuel Economy and Environment**

**Electric Vehicle**

These estimates reflect new EPA methods beginning with 2017 models. Large cars range from 14 to 95 MPGe. The best vehicle rates 119 MPGe.

**Fuel Economy**

**104** MPGe

combined city/hwy

101 city    107 highway    32 kW-hrs per 100 miles

**Driving Range**

When fully charged, vehicle can travel about...

Charge Time: 10 hours (240V)

**You save**

**\$3,750**

**in fuel costs over 5 years**

compared to the average new vehicle.

**Annual fuel cost**

**\$650**

**Fuel Economy & Greenhouse Gas Rating** (tailpipe only)

**Smog Rating** (tailpipe only)

This vehicle emits 0 grams CO<sub>2</sub> per mile. The best vehicle emits 0 grams per mile (tailpipe only). Producing and distributing fuel also create emissions; learn more at fueleconomy.gov.

Actual results will vary for many reasons, including driving conditions and how you drive and maintain your vehicle. The average new vehicle gets 26 MPG and costs \$7,000 to fuel over 5 years. Cost estimates are based on 15,000 miles per year at 0.13 per kW-hr. MPGe is miles per gasoline gallon equivalent. Vehicle emissions are a significant cause of climate change and smog.

**fueleconomy.gov**

Calculate personalized estimates and compare vehicles

Smartphone QR Code™

<http://fueleconomy.gov/g/75d2017TSL003>

P100D

**EPA DOT Fuel Economy and Environment** **Electric Vehicle**

These estimates reflect new EPA methods beginning with 2017 models.

**Fuel Economy** **98 MPGe** **You save \$3,750**  
 combined city/hwy Large cars range from 14 to 95 MPGe. The best vehicle rates 119 MPGe. **in fuel costs over 5 years**  
 compared to the average new vehicle.

**92** city **105** highway **35** kW-hrs per 100 miles

**Driving Range**  
 When fully charged, vehicle can travel about... **315** miles

Charge Time: 12 hours (240V)

**Annual fuel cost \$650**

**Fuel Economy & Greenhouse Gas Rating** (tailpipe only) **Smog Rating** (tailpipe only)

**1** **10** **10** **10** Best

This vehicle emits 0 grams CO<sub>2</sub> per mile. The best vehicle emits 0 grams per mile (tailpipe only). Producing and distributing fuel also create emissions; learn more at fueleconomy.gov.

Actual results will vary for many reasons, including driving conditions and how you drive and maintain your vehicle. The average new vehicle gets 26 MPG and costs \$7,000 to fuel over 5 years. Cost estimates are based on 15,000 miles per year at 0.13 per kW-hr. MPGe is miles per gasoline gallon equivalent. Vehicle emissions are a significant cause of climate change and smog.

**fueleconomy.gov**  
 Calculate personalized estimates and compare vehicles

Smartphone QR Code™   
<http://fueleconomy.gov/qr?id=2017TSL007>

100D

**EPA DOT Fuel Economy and Environment** **Electric Vehicle**

These estimates reflect new EPA methods beginning with 2017 models.

**Fuel Economy** **102 MPGe** **You save \$3,750**  
 combined city/hwy Large cars range from 14 to 95 MPGe. The best vehicle rates 119 MPGe. **in fuel costs over 5 years**  
 compared to the average new vehicle.

**101** city **102** highway **33** kW-hr per 100 miles

**Driving Range**  
 When fully charged, vehicle can travel about... **335** miles

Charge Time: 12 hours (240V)

**Annual fuel cost \$650**

**Fuel Economy & Greenhouse Gas Rating** (tailpipe only) **Smog Rating** (tailpipe only)

**1** **10** **10** **10** Best

This vehicle emits 0 grams CO<sub>2</sub> per mile. The best emits 0 grams per mile (tailpipe only). Producing and distributing fuel also create emissions; learn more at fueleconomy.gov.

Actual results will vary for many reasons, including driving conditions and how you drive and maintain your vehicle. The average new vehicle gets 26 MPG and costs \$7,000 to fuel over 5 years. Cost estimates are based on 15,000 miles per year at 0.13 per kW-hr. MPGe is miles per gasoline gallon equivalent. Vehicle emissions are a significant cause of climate change and smog.

**fueleconomy.gov**  
 Calculate personalized estimates and compare vehicles

Smartphone QR Code™   
<http://fueleconomy.gov/qr?id=2017TSL009>

## 07.04 Projected sales information

P90D US – [ ]

CA – [ ]

90D US – [ ]

CA – [ ]

75D US – [ ]

CA – [ ]

60 D – US [ ]

CA – [ ]

P100D US – [ ]

CA - [ ]

**100D** US – [ ]

CA - [ ]

## 08.00 GENERAL TECHNICAL DESCRIPTION

08.01

### ***Description of propulsion system***

The Tesla Model S propulsion system consists of two drive units and a high voltage battery pack. Each drive unit contains a traction motor, a fixed gearbox, and the drive inverter.

The Model S front drive unit is connected to the rear wheels via a fixed ratio transmission through the independent suspension-equipped rear axle.

The Model S rear drive unit is connected to the rear wheels via a fixed ratio transmission through the independent suspension-equipped rear axle.

08.02

### ***Description of motor(s)***

The Tesla motors are both 3-phase AC induction motors utilizing a four-pole, high-frequency design with inverter-controlled magnetic flux. Two versions of the motor are available; the Base motor and a sport motor.

08.03

### ***Description of batteries***

The battery packs used in the Tesla Model S is one of the largest and technically most advanced lithium-ion battery packs in the world. Using customized automotive grade lithium-ion cells, the Tesla battery achieves unmatched energy density and enables the long range capability of the vehicle. The low-profile flat packaging enables an efficient and functional occupant area. The battery has a replaceable fuse that is accessible with the battery removed from the vehicle and a set of contactors inside the pack that disconnect high voltage from the positive and negative terminals on the battery pack. To disable contactors from closing during vehicle service, the 12V power feed can be disconnected in the vehicle fuse box. The battery control system consists of the Battery Monitoring System (BMS) which controls the contactors, measures pack current and voltages, electrical isolation of the battery from chassis ground and monitors cell brick voltages, module temperatures, and faults from the Battery Monitor Boards (BMBs) installed on each of the many modules. The battery is rated at 400V and is capable of delivering in excess of 1000 Amperes. The battery mass is greater than 500 kg.

08.03.01 **Battery charging capacity**

The battery when fully charged contains the approximate amount of energy based on the type of battery fitted onto the vehicle.

08.03.02 **Self-discharge information**

The self-discharge rate of the battery is likely to be less than 4% per month.

08.03.03 **Description of thermal management system**

The Tesla battery pack contains an integrated cooling system to ensure that the individual cells are maintained at, or close to, their optimum operating temperature. Incorporated in the vehicle system is an inline heating element to raise and a chiller to lower the pack temperature, when required.

08.03.04 **Definition of end-of-life**

The battery pack end-of-life shall be determined by Tesla's local service centers with Proper inspection and test methods.

08.03.05 **Description of battery disposal plan**

Tesla's lithium ion battery packs do not contain heavy metals such as lead, Cadmium, or mercury. They are exempt from hazardous waste disposal standards in the USA under the Universal Waste Regulations. However, they do contain recyclable materials, and Tesla plans to recycle all battery packs removed from vehicles.

Tesla highly recommends that all battery packs be taken to local Tesla service facilities and recycled by Tesla or Tesla authorized agencies, so that the battery packs can be recycled in a safe and efficient manner.

If disposing independently, without return to Tesla, then the owner must assume responsibility for recycling in a safe and legal manner. If an owner does assume this responsibility, Tesla recommends consulting with the appropriate local, state or federal authorities to determine the appropriate methods for disposal and recycling. Keep in mind that disposal regulations may vary dependent on location.

For more information on the recycling of Tesla custom battery packs, please call Tesla Customer Service at 1-877-79TESLA (1-877-798-3752).

08.04 **Description of controller / inverter**

The drive inverter performs several critical functions in the Tesla Model S including torque control, power and torque limit enforcement, and status monitoring. The drive inverter is an integral part of the drive unit.

08.05 **Description of transmission**

The Tesla Model S transmission is a fixed ratio, mechanical, transversely mounted gearbox with integral final drive unit (transaxle configuration).

The shift lever is mounted to the steering column. The lever has four detents—one reverse, one drive, and two neutral positions. Selecting either forward or reverse position enables drive current to the motor to generate the appropriate torque. There is no physical reverse gear needed.

In addition, the lever has a park button which is used to operate the electrically-actuated park brake.

08.06 **Description of climate control system**

General Specifications:

The Model S climate control is a Dual Zone system with Automatic Temperature control. The modes include Defrost (Panel, Floor and any combination of these three). The system consists of four panel vents, two front row floor vents, defroster vent, second row floor vents, second row console vents with positive air shut off and turning vane manual control.

08.06.01 **Electric cabin heater**

The heater unit incorporating a variable speed electric fan is located in the front of the chassis tub with ducting directing the blown air to defrosting, face level and floor level vents in the passenger compartment. The heater element is of the positive temperature coefficient (PTC) type, drawing HV electrical energy from the battery pack High Voltage

08.06.02 **Fuel-fired heater**

Not applicable

08.06.03 **Air conditioning**

The Model S air conditioner system is an R134a refrigerant consists of a high voltage electric scroll type with integrated inverter with High Voltage Interlock Loop. The compressor Oil is Poly Olefin Ester oil that is non-conducting.

08.06.04 **Climate control system logic**

Remote Climate Control Module printed circuit board activates actuators and responds to evaporator air outlet temperature sensor, PTC heater outlet temperature sensor and air duct temperature sensors, as well as user demands from center display.

08.06.05 **Tamper resistance of climate control system that includes a fuel-fired heater**

Not applicable.

08.07 **Description of regenerative braking system**

Regenerative braking (RGB) occurs when the driver lifts their foot from the accelerator pedal while the vehicle is moving; the experience is analogous to engine braking on a gasoline-powered car with a conventional manual transmission. Because the Tesla Model S is a rear wheel drive vehicle, the system applies torque only to the rear wheels of the vehicle. The friction braking system of the Tesla Model S is independent of RGB.

The amount of RGB torque generated is proportional to accelerator pedal position – full torque when the accelerator pedal is fully released; less as the pedal is depressed, reaching zero torque when the pedal reaches its neutral torque position (a position that is in fact a function of vehicle speed). The max RGB deceleration also varies depending on vehicle speed. The maximum RGB profile is defined as a target total deceleration rate as a function of vehicle speed. The max RGB profile is tailored to everyday driving conditions, which typically exhibit higher deceleration rates at lower speeds.

When the battery pack is near maximum capacity, regenerative braking function will be limited to ensure the maximum capacity of the battery is not exceeded. Any RGB limiting will be ramped in gradually to allow the driver to adapt to the changing RGB performance. When the battery pack is below 0 degrees, RGB will not be allowed because the batteries are not rated to accept charge below this temperature. Any RGB limiting will be ramped in gradually to allow the driver to adapt to the changing RGB performance. . The vehicle notifies the driver of any limits of the regenerative braking function.

08.08 **Description of vehicle electrical supply equipment (charger)**

The Tesla Model S is capable of accepting energy either from a permanent facility installed at the owners location or from many readily available power outlets when 'on the road'.

The dedicated High Power Connector (HPC) can be purchased separately from the vehicle and a certified electrician will confirm the capabilities of the residential supply circuit at the vehicle owner's location. Confirmation of a satisfactory residential electrical

Supply will lead to the installation of a hard-wired HPC unit, this will expedite vehicle charging at the most efficient rate. The HPC can supply available current up to a maximum of 80 amps and incorporates electronic systems that communicate with the vehicle control systems to indicate the maximum available current so that the vehicle can determine the amount and rate of charge required.

Charging at rates lower than 80A can also be achieved via a mobile connector. The universal mobile connector is included as standard in the purchase of every Model S and is an individual cable that connects the vehicle to any available domestic power outlet and can deliver current to a maximum of 40 amps. The Mobile Connector incorporates the same electronic circuitry as the HPC to communicate with the vehicle and manage the charging process.

The vehicle is also capable of accepting DC current up to 225A from an off-board charger (Supercharger).

08.08.01 ***Proper recharging procedures***

The charging system adjusts automatically to the available AC line voltage, frequency and current, within limits. The charging system in the vehicle works in conjunction with either of the three external charging stations; the permanently installed HPC, the permanently installed supercharger or the portable Mobile Connector.

Anytime the EV Inlet door is opened, the vehicle will prepare to enter CHARGE state. Once the user connects either supply cable to the vehicle, the charging system signals to the vehicle that it is ready to deliver the charge. The vehicle locks the cable onto the vehicle and then indicates that it is ready to accept energy and charging will commence. Failure of any of these steps will result in fault condition and lack of charge.



Prepare to charge state



Charging Indication

If the battery temperature is near or below freezing temperatures, normal charging will not occur. The vehicle will identify this condition and will begin heating the battery coolant and circulating the coolant to raise the battery temperature to enable charge. When the pack temperature rises to a temperature within the allowable charging range, heating will reduce or stop and charging will commence.

08.08.02 **Power requirements necessary to recharge vehicle**  
 If there are two on-board chargers installed in the vehicle it is designed to accept AC current from 110-120V or 208-240V outlets with a supply of up to 80A. If there is a single on-board charger installed in the vehicle, then the AC current will be limited to 40A.

08.10 **Other unique features (i.e. solar panels)**  
 Not applicable; vehicle is not equipped with any such features.

08.11 **Description of warning system(s) for maintenance / malfunction**  
 The Tesla Model S is equipped with a tell-tale lamp located in the instrument pack to indicate battery malfunctions; the lamp illuminates yellow for a minor defect and red for a major fault.

The tell-tale is complemented by more detailed information exhibited on the 17" Center Display. An additional driver aid which indicates the nature of the malfunction as well as a wide range of additional vehicle data, such as when maintenance is needed.

08.11.01 **Cut-off terminal voltages for prevention of battery damage**  
 The control electronics inside of the Drive Unit and Charger are programmed not to allow the unit to drive the voltage of the battery above or below hard voltage limits. If the battery pack is unable to achieve a desired response from these systems and the voltage reaches above or below a set limit, the two contactors inside the battery pack will open, disabling the entire high voltage system in the car.

**09.00 Running Change vehicle description**

**09.01 New model 100D is added**

**09.02 New 75 kWh FW limited battery pack configuration**

"80P" battery configuration is now added with 75 model carline. 100 kWh battery pack module with depopulated cells and firmware limits to match 75 kWh pack performance. We still continue to produce 75 model carline with existing battery configuration.

As agreed with EPA Tesla ran pack level energy comparison between new "80P" pack and current 75 pack. The results are shown below.

The Estimated Test Weight of vehicle equipped with new "80P" pack has not changed. With the higher energy content of the 80p pack, the current 75 pack will still continue to be the worst case for FE label purposes.

|                            | 75kwh Standard | 75kwh "80p" pack |
|----------------------------|----------------|------------------|
| Starting SOC (%)           | 94.84          | 97.64            |
| Ending SOC (%)             | 6.126          | 5.65             |
| SOC consumed               | 88.714         | 91.99            |
| AH discharged (Ah)         | 213            | 241              |
| kWh discharged (kWh)       | 64.92          | 73.35            |
| Normalized Ah Total (Ah)   | 240.1          | 262.0            |
| Normalized kWh Total (kWh) | 73.2           | 79.7             |

10.00 Road load data – See Verify application.

**11.00 STARTING AND SHIFTING SCHEDULES**

**11.01 Starting**

The Model S does not have a traditional starter switch and instead has a smart entry system for greater safety and customer convenience. The smart entry system comprises of a smart key, a weight sensor embedded into the driver seat, and the brake pedal. When the driver enters the vehicle with the smart key and sits on the driver's seat, the vehicle controller, attempts to validate the unique key code by reading the key code. If successful interaction between the coded key and vehicle controller occurs, the system deactivates the immobilizer. The vehicle then enters accessory mode analogous to a "ACC" position on a conventional IC engine. In this mode, low voltage (12V) is supplied to the vehicle allowing operation of the radio and other accessories connected to the accessory rail. High Voltage (HV) necessary to enable vehicle propulsion is enabled only by the closing of the contactors, which can only be triggered when the following conditions are both satisfied,

1. Smart key is detected and key code is validated AND
2. Brake pedal is depressed.

By requiring brake pedal activation, along with the appropriate key code, this system ensures the safety of vehicle occupants by not allowing self mobility of the vehicle without the driver providing proper control inputs (i.e., service brake activation) and appropriate driver authorization (i.e., presence of the key code). If either the service brake is not activated or the key code not present, the vehicle controller will not close the connectors and self-mobility is not possible.

If the brake pedal is depressed and the proper key code present, the drive rail will activate and allows the transmission to be shifted out of Park.

**11.02 Shifting**

Not applicable – the vehicle has a single-speed transmission.

**12.00**

**16.00 RESERVED**

**17.00 CALIFORNIA REQUIREMENTS**

**17.01 Statement of compliance**

**17.01.01 General statement**

The production vehicles which are subject to registration or sale in the State of California will be, in all material respects, substantially the same in construction as test vehicles which are certified by the California Air Research Board; and will meet all the applicable emissions standards which are promulgated by the California Air Research Board in accordance with Section 43101 of the Health and Safety Code.

Tesla attests that the vehicle emission control label complies with the label durability requirements of the "California Motor Vehicle Emission Control and Smog Index Label Specifications", Title 13, CCR, Section 1965.

**17.01.02 Drivability statement**

This statement is no longer included in the California Exhaust Emission Standards and Test Procedures for 2001 and Subsequent Model Passenger Cars, Light-Duty Trucks, and Medium-Duty Vehicles (as of January 01 2006); as was the case in previous versions.

**17.02 Supplemental data and certification review sheets**

See attached

17.03 **Engineering evaluation of zero evaporative emissions under any and all operating conditions (for vehicles equipped with fuel-fired heater only)**

Not applicable; vehicle is not equipped with fuel-fired heater.

17.04 **Credits**

17.04.01 **Description of multi-manufacturer arrangements**

Not applicable; Tesla has no such agreements in place.

17.04.02 **Credit calculation**

Tesla a manufacturer that produces only pure battery electric vehicles is not required to produce a percentage of annual production volume as ZEV's and therefore will earn such credit on all 2013 to 2018, inclusive, model year vehicles. This vehicle is a full function ZEV with a range depending on the battery pack option chosen by the customer. Based on the UDDS of range shown in the table below, all variants will be classified as a Type III ZEV and Under the table in 13 CCR 1962.1(d)(5)(C), this means 2013 to 2017, each vehicle will earn 4 credits per vehicle

| Variant | UDDS range (miles) |
|---------|--------------------|
| P90D    | 356.2              |
| 90D     | 384                |
| 75D     | 345.5              |
| 60D     | 291.32             |
| P100D   | 414                |
| 100D    | 449.8              |

17.05 **Vehicle safety**

17.05.01 **All information for safe operation of vehicle**

Tesla will submit a copy of the finalized vehicle owner's handbook by separate letter when it becomes available.

17.05.02 **Information on safe handling of battery system**

#### HANDLING

Do not short circuit, puncture, incinerate, crush, immerse, force discharge, or expose the battery pack to temperatures outside the specified maximum storage temperature range of -20°C to 60°C.

The battery pack has a nominal operating voltage of 400 VDC. The battery pack is sealed in a rigid metal case and its exterior is isolated from high voltage. Handling the battery pack is electrically safe provided the enclosure remains closed.

The battery pack contains hermetically sealed lithium ion cells that contain a number of chemicals and materials of construction. Risk of exposure to electrode materials and Liquid electrolyte will only occur in cases of mechanical or thermal abuse of the battery Pack.

#### STORAGE

Do not store the battery pack in a manner that allows terminals to short circuit. Do not place near heating equipment, nor expose to direct sunlight for long periods. The battery pack should only be stored in approved packaging and stacked no more than two (2) packages high. To maintain service life, the battery pack should be stored at a state of charge (SOC) of 15 to 50%.

#### TRANSPORT

Lithium ion batteries are regulated as Class 9 Miscellaneous dangerous goods (also known as "hazardous materials") pursuant to the International Civil Aviation Organization

(ICAO) Technical Instructions for the Safe Transport of Dangerous Goods by Air, International Air Transport Association (IATA) Dangerous Goods Regulations, the International Maritime Dangerous Goods (IMDG) Code, European Agreements concerning the International Carriage of Dangerous Goods by Rail (RID) and Road (ADR), and applicable national regulations such as the USA's hazardous materials regulations (see 49 CFR 173.185). These regulations contain very specific packaging, labelling, marking, and documentation requirements. The regulations also require that individuals involved in the preparation of dangerous goods for transport be trained on how to properly package, label, mark and prepare shipping documents.

17.05.03

### ***Description of emergency procedures***

#### **HIGH VOLTAGE EXPOSURE**

If one of the Tesla products has been visibly damaged or its enclosure compromised, then practice appropriate high voltage preventative measures until the danger has been assessed (and dissipated if necessary).

#### **FIREFIGHTING MEASURES**

If a fire or explosion occurs when the battery pack is charging, shut off power to the charger. In case of burning lithium ion fires, flood the area with water. The water may not extinguish them, but will cool the adjacent batteries and control the spread of the fire. CO<sub>2</sub>, dry chemical and foam extinguishers are preferred for small fires, but also may not extinguish burning lithium ion batteries. Burning batteries will burn themselves out. Virtually all fires involving lithium ion batteries can be controlled with water. When water is used, however, hydrogen gas may be a by-product which can form an explosive Mixture with air. LITH-X (powdered graphite) or copper powder fire extinguishers, sand, dry ground dolomite or soda ash may also be used. These materials act as smothering agents.

Damaged or opened cells or batteries can result in rapid heating (due to exothermic reaction of constituent materials) and the release of flammable vapors. Water (and other items listed above) disperses heat when applied in sufficient quantity to a fire. Extended heat exposure can lead to ignition of adjacent cells with a potential complete envelopment of the battery pack if not cooled. An extinguished lithium ion battery fire can re-ignite due to the exothermic reaction of constituent materials from broken or damaged cells. To avoid this, remove sources of ignition and cool the burned mass by flooding with (or immersing in) water. Fire-fighters should wear self-contained breathing apparatus. Cells or batteries may flame or leak potentially hazardous organic vapors if exposed to excessive heat, fire or over voltage conditions. These vapors include HF, oxides of carbon, aluminum, lithium, copper, and cobalt. Additionally, volatile phosphorus pentafluoride may form at temperatures above 230° Fahrenheit.

Never cut into the sealed battery pack enclosure due to the high voltage and electrocution risks.

If a decision is made to fight a battery fire aggressively, then large amounts of water should be applied from a safe distance with the intent of flooding the battery pack enclosure as completely as possible. Alternatively, if a decision is made to fight a battery fire defensively, then the fire crew should pull back a safe distance and allow the battery to burn itself out. Fire crews may choose to utilize a water stream or fog pattern to protect exposures or control the path of smoke.

#### **FIRST AID MEASURES**

Under normal conditions of use, the constituent battery cells are hermetically sealed. Contents of an open (broken) constituent battery cell can cause skin irritation and/or chemical burns.

If materials from a ruptured or otherwise damaged cell or battery contact skin, flush immediately with water and wash affected area with soap and water. For eye contact, flush with significant amounts of water for 15 minutes and see physician at once. Avoid inhaling any vented gases. If a chemical burn occurs or if irritation persists, seek medical assistance.

Seek immediate medical assistance if an electrical shock or electrocution has occurred (or is suspected).\

17.06      **Description of fuel-fired heater / fuel tank evaporative system**  
Not applicable; vehicle is not equipped with fuel-fired heater.

## **18.00 FUEL ECONOMY DATASETS**

### **P90D (DP316-L2S/0)**

CD UDDS Test (Test # GTSLV)  
AC Recharge Energy: 96.65 kWh  
(AER) Unadjusted: 356.2 miles  
CO2 Composite Adjusted: 0 g/mi (factors into 0 g/mi on FE label)

CD Highway Test (Test # GTSL)  
AC Recharge Energy: 96.46 kWh  
(AER) Unadjusted: 388.51 miles  
CO2 Composite Adjusted: 0 g/mi (factors into 0 g/mi on FE label)

### **90D (DS316-L2S/0)**

CD UDDS Test (Test #GTSL)  
AC Recharge Energy: 96.08 kWh  
(AER) Unadjusted: 384.00 Miles  
CO2 Composite Adjusted: 0 g/mi (factors into 0 g/mi on FE label)

CD Highway Test (Test # FTSL10034588)  
AC Recharge Energy: 96.66 kWh  
(AER) Unadjusted: 405.2 miles  
CO2 Composite Adjusted: 0 g/mi (factors into 0 g/mi on FE label)

### **75D (DS216-L2S/0)**

CD UDDS Test (Test # )  
AC Recharge Energy: 84.48 kWh  
(AER) Unadjusted: 345.58 Miles  
CO2 Composite Adjusted: 0 g/mi (factors into 0 g/mi on FE label)

CD Highway Test (Test # )  
AC Recharge Energy: 84.65 kWh  
(AER) Unadjusted: 358.49 miles  
CO2 Composite Adjusted: 0 g/mi (factors into 0 g/mi on FE label)

**60D (DS116-L2S/0)**

CD UDDS Test (Test # )  
AC Recharge Energy: 71.22 kWh  
(AER) Unadjusted: 291.32 Miles  
CO2 Composite Adjusted: 0 g/mi (factors into 0 g/mi on FE label)

CD Highway Test ( )  
AC Recharge Energy: 71.36 kWh  
(AER) Unadjusted: 302.21 miles  
CO2 Composite Adjusted: 0 g/mi (factors into 0 g/mi on FE label)

**P100D (DP416-L2S/0)**

CD UDDS Test (Test # )  
AC Recharge Energy: 111.47 kWh  
(AER) Unadjusted: 414.45 Miles  
CO2 Composite Adjusted: 0 g/mi (factors into 0 g/mi on FE label)

CD Highway Test ( )  
AC Recharge Energy: 111.88 kWh  
(AER) Unadjusted: 469.99 miles  
CO2 Composite Adjusted: 0 g/mi (factors into 0 g/mi on FE label)

**100D (DS417-172225)**

CD UDDS Test (Test # HTSL10046798)  
AC Recharge Energy: 113.201 kWh  
(AER) Unadjusted: 449.76 Miles  
CO2 Composite Adjusted: 0 g/mi (factors into 0 g/mi on FE label)

CD Highway Test (Test #  
HTSL10046799)  
AC Recharge Energy: 113.201 kWh  
(AER) Unadjusted: 455.37 miles  
CO2 Composite Adjusted: 0 g/mi (factors into 0 g/mi on FE label)

2017 MODEL-YEAR AIR  
 RESOURCES BOARD  
 SUPPLEMENTAL DATA SHEET  
 ZEV-PASSENGER CARS, LIGHT-DUTY TRUCKS AND MEDIUM DUTY VEHICLES  
**P90D**

Manufacturer: Tesla, Inc. Engine Family: HTSLV00.0L2S

Vehicle Class (es): PC  LDT1 \_\_\_\_\_ LDT2 \_\_\_\_\_ MDV2 \_\_\_\_\_ MDV3 \_\_\_\_\_ MDV4 \_\_\_\_\_ MDV5 \_\_\_\_\_

Number of ZEV Credits per vehicle: 4

Fuel Type: Electro-chemical Battery  Fuel Cell \_\_\_\_\_ Capacitor \_\_\_\_\_ Other (specify) \_\_\_\_\_

Battery Type(s): Lead Acid \_\_\_\_\_ Nickel Cadmium \_\_\_\_\_ SBLA \_\_\_\_\_ Sodium Sulphur \_\_\_\_\_

Sodium Nickel Chloride \_\_\_\_\_ Nickel Metal \_\_\_\_\_ Lithium Metal Disulfide \_\_\_\_\_

Zinc Air \_\_\_\_\_ Zinc Bromine \_\_\_\_\_ Lithium Ion  Other (specify) \_\_\_\_\_

Total Battery Weight 580 kg Total Battery Volume 0.400 m<sup>3</sup> Battery Specific Energy 150 Wh/kg

Number of batteries or modules per vehicle: 1 (one) Total Battery Voltage: 350 nominal

Charger(s): On-Board  Off-board \_\_\_\_\_ Conductive  Inductive \_\_\_\_\_

Drive Motor(s): AC Induction  DC Brush \_\_\_\_\_ DC Brushless \_\_\_\_\_

Switched Reluctance \_\_\_\_\_ Other (specify) \_\_\_\_\_

Number of Drive Motor(s): 2 (Two) Rated Motor Power 193 / 375KW @ 7,000 rpm Max rpm 14,000

Drive: FWD \_\_\_\_\_ RWD \_\_\_\_\_ 4WD-FT  4WD-PT \_\_\_\_\_

Regenerative Braking: No \_\_\_\_\_ Yes  FW \_\_\_\_\_ RW  AW \_\_\_\_\_

Driver Controlled Regen Braking: Yes \_\_\_\_\_ No  Coast Regen Braking: Yes  No \_\_\_\_\_

Air Conditioning: Yes  No \_\_\_\_\_

Fuel-fired Heater: No \_\_\_\_\_ Fuel Type: Gas \_\_\_\_\_ Diesel \_\_\_\_\_ CNG \_\_\_\_\_ LNG \_\_\_\_\_

LPG \_\_\_\_\_ Other (specify) \_\_\_\_\_ Rated Heat Power: \_\_\_\_\_ kW

| Vehicle Models<br>(if coded, see<br>attachments) | Transmission<br>Type; M5, A4<br>(if applicable) | GVWR<br>kg (lbs) | Curb Weight<br>kg (lbs) | ETW<br>or<br>Test Weight<br>kg (lbs) | DPA / RLHP<br>or<br>Dyno Coefficient<br>a=, b=, c= |
|--|---|------------------|-------------------------|--------------------------------------|--|
| P90D   | A1  | 2670 (5874)      | 2196 (4840)             | 2380 (5250)                          | a=41.51, b=0.2226,<br>c= 0.01403                   |

2017 MODEL-YEAR AIR  
RESOURCES BOARD  
SUPPLEMENTAL DATA SHEET  
ZEV-PASSENGER CARS, LIGHT-DUTY TRUCKS AND MEDIUM DUTY VEHICLES  
**P90D**

Manufacturer: Tesla, Inc.

Engine Family: HTSLV00.0L2S

| Range Test Results: |       |  |   |                  |                           |                           |                            |
|---------------------|-------|--|---|------------------|---------------------------|---------------------------|----------------------------|
| Vehicle ID          | Trans | (check one)<br>_____<br>TW<br>_____<br>X ETW | (check one)<br>_____<br>DPA<br>_____<br>X RLHP<br>or Dyno Coefficient | City<br>Range    | System<br>AC<br>(Wh/mile) | System<br>DC<br>(Wh/mile) | Vehicle<br>DC<br>(Wh/mile) |
| DP316-L2S<br>/0     | n/a   | 5250   | 11.70   | 356.2            | 268.5                     | 234.76                    | 234.76                     |
|                     |       |  |   | Highway<br>Range | System<br>AC<br>(Wh/mile) | System<br>DC<br>(Wh/mile) | Vehicle<br>DC<br>(Wh/mile) |
|                     |       |  |   | 388.51           | 248.20                    | 216.72                    | 216.72                     |

Battery Test Results: Specific Energy: 150 \* Wh/kg \_\_\_\_\_

Fuel-fired Heater Test Results (emission results in grams / mile): Not applicable

| <u>NMHC</u>    | <u>CO</u>      | <u>NOx</u>     |
|----------------|----------------|----------------|
| Not applicable | Not applicable | Not applicable |

2017 MODEL-YEAR  
 AIR RESOURCES BOARD  
 SUPPLEMENTAL DATA SHEET  
 ZEV-PASSENGER CARS, LIGHT-DUTY TRUCKS AND MEDIUM DUTY VEHICLES  
**90D**

Manufacturer: Tesla, Inc. Engine Family: HTSLV00.0L2S

Vehicle Class(es): PC  LDT1 \_\_\_\_\_ LDT2 \_\_\_\_\_ MDV2 \_\_\_\_\_ MDV3 \_\_\_\_\_ MDV4 \_\_\_\_\_ MDV5 \_\_\_\_\_

Number of ZEV Credits per vehicle: 4

Fuel Type: Electro-chemical Battery  Fuel Cell \_\_\_\_\_ Capacitor \_\_\_\_\_ Other (specify) \_\_\_\_\_

Battery Type(s): Lead Acid \_\_\_\_\_ Nickel Cadmium \_\_\_\_\_ SBLA \_\_\_\_\_ Sodium Sulphur \_\_\_\_\_

Sodium Nickel Chloride \_\_\_\_\_ Nickel Metal \_\_\_\_\_ Lithium Metal Disulfide \_\_\_\_\_

Zinc Air \_\_\_\_\_ Zinc Bromine \_\_\_\_\_ Lithium Ion  Other (specify) \_\_\_\_\_

Total Battery Weight 580 kg Total Battery Volume 0.400 m<sup>3</sup> Battery Specific Energy 150 Wh/kg

Number of batteries or modules per vehicle: 1 (one) Total Battery Voltage: 350 nominal

Charger(s): On-Board  Off-board \_\_\_\_\_ Conductive  Inductive \_\_\_\_\_

Drive Motor(s): AC Induction  DC Brush \_\_\_\_\_ DC Brushless \_\_\_\_\_

Switched Reluctance \_\_\_\_\_ Other (specify) \_\_\_\_\_

Number of Drive Motor(s): 2 (Two) Rated Motor Power 193 (front) @ 7,000 rpm Max rpm 14,000  
193 (Rear)

Drive: FWD \_\_\_\_\_ RWD \_\_\_\_\_ 4WD-FT  4WD-PT \_\_\_\_\_

Regenerative Braking: No \_\_\_\_\_ Yes  FW \_\_\_\_\_ RW  AW \_\_\_\_\_

Driver Controlled Regen Braking: Yes \_\_\_\_\_ No  Coast Regen Braking: Yes  No \_\_\_\_\_

Air Conditioning: Yes  No \_\_\_\_\_

Fuel-fired Heater: No \_\_\_\_\_ Fuel Type: Gas \_\_\_\_\_ Diesel \_\_\_\_\_ CNG \_\_\_\_\_ LNG \_\_\_\_\_

LPG \_\_\_\_\_ Other (specify) \_\_\_\_\_ Rated Heat Power: \_\_\_\_\_ kW \_\_\_\_\_

| Vehicle Models<br>(if coded, see<br>attachments) | Transmission<br>Type; M5, A4<br>(if applicable) | GVWR<br>kg (lbs) | Curb Weight<br>kg (lbs) | ETW<br>or<br>Test Weight<br>kg (lbs) | DPA / RLHP<br>or<br>Dyno Coefficient<br>a=, b=, c= |
|--|---|------------------|-------------------------|--------------------------------------|--|
| 90D  | A1  | 2640 (5808)      | 2172 (4789)             | 2267 (5000)                          | a=39.24, b=0.1493,<br>c= 0.01514                   |

2017 MODEL-YEAR  
AIR RESOURCES BOARD  
SUPPLEMENTAL DATA SHEET  
ZEV-PASSENGER CARS, LIGHT-DUTY TRUCKS AND MEDIUM DUTY VEHICLES  
**90D**

Manufacturer: Tesla, Inc.

Engine Family: HTSLV00.0L2S

| Range Test Results: |       |   |  |                  |                           |                           |                            |
|---------------------|-------|---|--|------------------|---------------------------|---------------------------|----------------------------|
| Vehicle ID          | Trans | (check one)<br>TW<br><input checked="" type="checkbox"/> ETW<br>_____ | (check one)<br>DPA<br><input checked="" type="checkbox"/> RLHP<br>or <small>Dyno Coefficient</small> | City<br>Range    | System<br>AC<br>(Wh/mile) | System<br>DC<br>(Wh/mile) | Vehicle<br>DC<br>(Wh/mile) |
| DS316-L2S<br>/0     | n/a   | 5000  | 11.27  | 384.00           | 250.02                    | 218.57                    | 218.57                     |
|                     |       |   |  | Highway<br>Range | System<br>AC<br>(Wh/mile) | System<br>DC<br>(Wh/mile) | Vehicle<br>DC<br>(Wh/mile) |
|                     |       |   |  | 405.2            | 238.50                    | 208.02                    | 208.02                     |

Battery Test Results:      Specific Energy:      150 \* Wh/kg \_\_\_\_\_

Fuel-fired Heater Test Results (emission results in grams / mile): Not applicable

| <u>NMHC</u>    | <u>CO</u>      | <u>NOx</u>     |
|----------------|----------------|----------------|
| Not applicable | Not applicable | Not applicable |

Remarks:  
Date issued:      Revisions:

----- ARB USE ONLY -----

Application      Date:      Reviewed by:      Date:  
Processed by:

2017 MODEL-YEAR  
AIR RESOURCES BOARD  
SUPPLEMENTAL DATA SHEET  
ZEV-PASSENGER CARS, LIGHT-DUTY TRUCKS AND MEDIUM DUTY VEHICLES  
**75D**

Manufacturer: Tesla, Inc.Engine Family: HTSLV00.0L2SVehicle Class(es): PC  LDT1  LDT2  MDV2  MDV3  MDV4  MDV5 Number of ZEV Credits per vehicle: 4Fuel Type: Electro-chemical Battery  Fuel Cell  Capacitor  Other (specify) \_\_\_\_\_Battery Type(s): Lead Acid  Nickel Cadmium  SBLA  Sodium Sulphur Sodium Nickel Chloride  Nickel Metal  Lithium Metal Disulfide Zinc Air  Zinc Bromine  Lithium Ion  Other (specify) \_\_\_\_\_Total Battery Weight 530 kg Total Battery Volume 0.400 m<sup>3</sup> Battery Specific Energy 141 Wh/kgNumber of batteries or modules per vehicle: 1 (one) Total Battery Voltage: 350 nominalCharger(s): On-Board  Off-board  Conductive  Inductive Drive Motor(s): AC Induction  DC Brush  DC Brushless Switched Reluctance  Other (specify) \_\_\_\_\_Number of Drive Motor(s): 2 (Two) Rated Motor Power 193 (front) @ 7,000 rpm Max rpm 14,000  
193 (Rear)Drive: FWD  RWD  4WD-FT  4WD-PT Regenerative Braking: No  Yes  FW  RW  AW Driver Controlled Regen Braking: Yes  No  Coast Regen Braking: Yes  No Air Conditioning: Yes  No Fuel-fired Heater: No Fuel Type: Gas  Diesel  CNG  LNG LPG  Other (specify) \_\_\_\_\_ Rated Heat Power: \_\_\_\_\_ kW

| Vehicle Models<br>(if coded, see<br>attachments) | Transmission<br>Type; M5, A4<br>(if applicable) | GVWR<br>kg (lbs) | Curb Weight<br>kg (lbs) | ETW<br>or<br>Test Weight<br>kg (lbs) | DPA / RLHP<br>or<br>Dyno Coefficient<br>a=, b=, c= |
|--|---|------------------|-------------------------|--------------------------------------|--|
| 75D  | A1  | 2639 (5820)      | 2141 (4723)             | 2267 (5000)                          | a=37.37, b=0.1842,<br>c= 0.01508                   |

Date issued:

Revisions:

2017 MODEL-YEAR  
 AIR RESOURCES BOARD  
 SUPPLEMENTAL DATA SHEET  
 ZEV-PASSENGER CARS, LIGHT-DUTY TRUCKS AND MEDIUM DUTY VEHICLES  
**75D**

Manufacturer: Tesla, Inc.

Engine Family: HTSLV00.0L2S

| Range Test Results: |       |  |   |                  |                           |                           |                            |
|---------------------|-------|--|---|------------------|---------------------------|---------------------------|----------------------------|
| Vehicle ID          | Trans | (check one)<br>TW<br><input checked="" type="checkbox"/> ETW | (check one)<br>DPA<br><input checked="" type="checkbox"/> RLHP<br>or Dyno Coefficient | City<br>Range    | System<br>AC<br>(Wh/mile) | System<br>DC<br>(Wh/mile) | Vehicle<br>DC<br>(Wh/mile) |
| DS216-L2S<br>/0     | n/a   | 5000   | 11.24   | 345.58           | 244.45                    | 210.57                    | 210.57                     |
|                     |       |  |   | Highway<br>Range | System<br>AC<br>(Wh/mile) | System<br>DC<br>(Wh/mile) | Vehicle<br>DC<br>(Wh/mile) |
|                     |       |  |   | 358.49           | 236.12                    | 205.02                    | 205.02                     |

Battery Test Results: Specific Energy: 141 \* Wh/kg

Fuel-fired Heater Test Results (emission results in grams / mile): Not applicable

| NMHC           | CO             | NOx            |
|----------------|----------------|----------------|
| Not applicable | Not applicable | Not applicable |

Remarks:

Date issued:

Revisions:

----- ARB USE ONLY -----

Application  
Processed by:

Date:

Reviewed by:

Date:

2017 MODEL-YEAR  
 AIR RESOURCES BOARD  
 SUPPLEMENTAL DATA SHEET  
 ZEV-PASSENGER CARS, LIGHT-DUTY TRUCKS AND MEDIUM DUTY VEHICLES  
**60D**

Manufacturer: Tesla, Inc. Engine Family: HTSLV00.0L2S

Vehicle Class(es): PC  LDT1 \_\_\_\_\_ LDT2 \_\_\_\_\_ MDV2 \_\_\_\_\_ MDV3 \_\_\_\_\_ MDV4 \_\_\_\_\_ MDV5 \_\_\_\_\_

Number of ZEV Credits per vehicle: 4

Fuel Type: Electro-chemical Battery  Fuel Cell \_\_\_\_\_ Capacitor \_\_\_\_\_ Other (specify) \_\_\_\_\_

Battery Type(s): Lead Acid \_\_\_\_\_ Nickel Cadmium \_\_\_\_\_ SBLA \_\_\_\_\_ Sodium Sulphur \_\_\_\_\_

Sodium Nickel Chloride \_\_\_\_\_ Nickel Metal \_\_\_\_\_ Lithium Metal Disulfide \_\_\_\_\_

Zinc Air \_\_\_\_\_ Zinc Bromine \_\_\_\_\_ Lithium Ion  Other (specify) \_\_\_\_\_

Total Battery Weight 530 kg Total Battery Volume 0.400 m<sup>3</sup> Battery Specific Energy 141 Wh/kg

Number of batteries or modules per vehicle: 1 (one) Total Battery Voltage: 350 nominal

Charger(s): On-Board  Off-board \_\_\_\_\_ Conductive  Inductive \_\_\_\_\_

Drive Motor(s): AC Induction  DC Brush \_\_\_\_\_ DC Brushless \_\_\_\_\_

Switched Reluctance \_\_\_\_\_ Other (specify) \_\_\_\_\_

Number of Drive Motor(s): 2 (Two) Rated Motor Power 193 (front) @ 7,000 rpm Max rpm 14,000  
193 (Rear)

Drive: FWD \_\_\_\_\_ RWD \_\_\_\_\_ 4WD-FT  4WD-PT \_\_\_\_\_

Regenerative Braking: No \_\_\_\_\_ Yes  FW \_\_\_\_\_ RW  AW \_\_\_\_\_

Driver Controlled Regen Braking: Yes \_\_\_\_\_ No  Coast Regen Braking: Yes  No \_\_\_\_\_

Air Conditioning: Yes  No \_\_\_\_\_

Fuel-fired Heater: No Fuel Type: Gas \_\_\_\_\_ Diesel \_\_\_\_\_ CNG \_\_\_\_\_ LNG \_\_\_\_\_

LPG \_\_\_\_\_ Other (specify) \_\_\_\_\_ Rated Heat Power: \_\_\_\_\_ kW

| Vehicle Models<br>(if coded, see<br>attachments) | Transmission<br>Type; M5, A4<br>(if applicable) | GVWR<br>kg (lbs) | Curb Weight<br>kg (lbs) | ETW<br>or<br>Test Weight<br>kg (lbs) | DPA / RLHP<br>or<br>Dyno Coefficient<br>a=, b=, c= |
|--|---|------------------|-------------------------|--------------------------------------|--|
| 60D  | A1  | 2639 (5820)      | 2141 (4723)             | 2267 (5000)                          | a=37.37, b=0.1842,<br>c= 0.01508                   |

Date issued:

Revisions:

2017 MODEL-YEAR  
 AIR RESOURCES BOARD  
 SUPPLEMENTAL DATA SHEET  
 ZEV-PASSENGER CARS, LIGHT-DUTY TRUCKS AND MEDIUM DUTY VEHICLES  
**60D**

Manufacturer: Tesla, Inc.

Engine Family: HTSLV00.0L2S

| Range Test Results: |       |   |   |                  |                           |                           |                            |
|---------------------|-------|---|---|------------------|---------------------------|---------------------------|----------------------------|
| Vehicle ID          | Trans | (check one)<br>TW<br><input checked="" type="checkbox"/> ETW<br>_____ | (check one)<br>DPA<br><input checked="" type="checkbox"/> RLHP<br>or Dyno Coefficient | City<br>Range    | System<br>AC<br>(Wh/mile) | System<br>DC<br>(Wh/mile) | Vehicle<br>DC<br>(Wh/mile) |
| DS116-L2S<br>/0     | n/a   | 5000  | 11.24   | 291.3            | 244.47                    | 210.57                    | 210.57                     |
|                     |       |   |   | Highway<br>Range | System<br>AC<br>(Wh/mile) | System<br>DC<br>(Wh/mile) | Vehicle<br>DC<br>(Wh/mile) |
|                     |       |   |   | 302.21           | 236.12                    | 205.02                    | 205.02                     |

Battery Test Results: Specific Energy: 141 \* Wh/kg

Fuel-fired Heater Test Results (emission results in grams / mile): Not applicable

| NMHC           | CO             | NOx            |
|----------------|----------------|----------------|
| Not applicable | Not applicable | Not applicable |

Remarks:  
Date issued:

Revisions:

----- ARB USE ONLY -----

Application  
Processed by:

Date:

Reviewed by:

Date:

2017 MODEL-YEAR  
AIR RESOURCES BOARD  
SUPPLEMENTAL DATA SHEET  
ZEV-PASSENGER CARS, LIGHT-DUTY TRUCKS AND MEDIUM DUTY VEHICLES  
**P100D**

Manufacturer: Tesla, Inc.Engine Family: HTSLV00.0L2SVehicle Class(es): PC  LDT1 \_\_\_\_\_ LDT2 \_\_\_\_\_ MDV2 \_\_\_\_\_ MDV3 \_\_\_\_\_ MDV4 \_\_\_\_\_ MDV5 \_\_\_\_\_Number of ZEV Credits per vehicle: 4Fuel Type: Electro-chemical Battery  Fuel Cell \_\_\_\_\_ Capacitor \_\_\_\_\_ Other (specify) \_\_\_\_\_

Battery Type(s): Lead Acid \_\_\_\_\_ Nickel Cadmium \_\_\_\_\_ SBLA \_\_\_\_\_ Sodium Sulphur \_\_\_\_\_

Sodium Nickel Chloride \_\_\_\_\_ Nickel Metal \_\_\_\_\_ Lithium Metal Disulfide \_\_\_\_\_

Zinc Air \_\_\_\_\_ Zinc Bromine \_\_\_\_\_ Lithium Ion  Other (specify) \_\_\_\_\_Total Battery Weight 625 kg Total Battery Volume 0.400 m<sup>3</sup> Battery Specific Energy 160 Wh/kgNumber of batteries or modules per vehicle: 1 (one) Total Battery Voltage: 350 nominalCharger(s): On-Board  Off-board \_\_\_\_\_ Conductive  Inductive \_\_\_\_\_Drive Motor(s): AC Induction  DC Brush \_\_\_\_\_ DC Brushless \_\_\_\_\_

Switched Reluctance \_\_\_\_\_ Other (specify) \_\_\_\_\_

Number of Drive Motor(s): 2 (Two) Rated Motor Power 193 (front) @ 7,000 rpm Max rpm 14,000  
375 (Rear)Drive: FWD \_\_\_\_\_ RWD \_\_\_\_\_ 4WD-FT  4WD-PT \_\_\_\_\_Regenerative Braking: No \_\_\_\_\_ Yes  FW \_\_\_\_\_ RW  AW \_\_\_\_\_Driver Controlled Regen Braking: Yes \_\_\_\_\_ No  Coast Regen Braking: Yes  No \_\_\_\_\_Air Conditioning: Yes  No \_\_\_\_\_

Fuel-fired Heater: No \_\_\_\_\_ Fuel Type: Gas \_\_\_\_\_ Diesel \_\_\_\_\_ CNG \_\_\_\_\_ LNG \_\_\_\_\_

LPG \_\_\_\_\_ Other (specify) \_\_\_\_\_ Rated Heat Power: \_\_\_\_\_ kW \_\_\_\_\_

| Vehicle Models<br>(if coded, see<br>attachments) | Transmission<br>Type; M5, A4<br>(if applicable) | GVWR<br>kg (lbs) | Curb Weight<br>kg (lbs) | ETW<br>or<br>Test Weight<br>kg (lbs) | DPA / RLHP<br>or<br>Dyno Coefficient<br>a=, b=, c= |
|--|---|------------------|-------------------------|--------------------------------------|--|
| P100D  | A1  | 2742 (6043)      | 2239 (4939)             | 2282 (5250)                          | a=41.35, b=0.2670,<br>c= 0.01370                   |

Date issued:

Revisions:

2017 MODEL-YEAR  
 AIR RESOURCES BOARD  
 SUPPLEMENTAL DATA SHEET  
 ZEV-PASSENGER CARS, LIGHT-DUTY TRUCKS AND MEDIUM DUTY VEHICLES  
**P100D**

Manufacturer: Tesla, Inc.

Engine Family: HTSLV00.0L2S

| Range Test Results: |       |  |   |                  |                           |                           |                            |
|---------------------|-------|--|---|------------------|---------------------------|---------------------------|----------------------------|
| Vehicle ID          | Trans | (check one)<br>TW<br><input checked="" type="checkbox"/> ETW | (check one)<br>DPA<br><input checked="" type="checkbox"/> RLHP<br>or Dyno Coefficient | City<br>Range    | System<br>AC<br>(Wh/mile) | System<br>DC<br>(Wh/mile) | Vehicle<br>DC<br>(Wh/mile) |
| D4416-L2S<br>/0     | n/a   | 5250   | 12.44   | 414.45           | 268.96                    | 236.99                    | 236.99                     |
|                     |       |  |   | Highway<br>Range | System<br>AC<br>(Wh/mile) | System<br>DC<br>(Wh/mile) | Vehicle<br>DC<br>(Wh/mile) |
|                     |       |  |   | 469.99           | 238.05                    | 210.00                    | 210.00                     |

Battery Test Results: Specific Energy: 160 \* Wh/kg

Fuel-fired Heater Test Results (emission results in grams / mile): Not applicable

| NMHC           | CO             | NOx            |
|----------------|----------------|----------------|
| Not applicable | Not applicable | Not applicable |

Remarks:  
Date issued:

Revisions:

RB USE ONLY

-----  
 Application  
 Processed by: \_\_\_\_\_ Date: \_\_\_\_\_ Reviewed by: \_\_\_\_\_ Date: \_\_\_\_\_

E.O.# \_\_\_\_\_ Page \_\_\_\_\_

2017 MODEL-YEAR AIR  
RESOURCES BOARD  
SUPPLEMENTAL DATA SHEET  
ZEV-PASSENGER CARS, LIGHT-DUTY TRUCKS AND MEDIUM DUTY VEHICLES

**100D**

Manufacturer: Tesla, Inc. Engine Family: HTSLV00.0L2S

Vehicle Class (es): PC X LDT1      LDT2      MDV2      MDV3      MDV4      MDV5     

Number of ZEV Credits per vehicle: 4

Fuel Type: Electro-chemical Battery X Fuel Cell      Capacitor      Other (specify)     

Battery Type(s): Lead Acid      Nickel Cadmium      SBLA      Sodium Sulphur     

Sodium Nickel Chloride      Nickel Metal      Lithium Metal Disulfide     

Zinc Air      Zinc Bromine      Lithium Ion X Other (specify)     

Total Battery Weight 625 kg Total Battery Volume 0.400 m<sup>3</sup> Battery Specific Energy 160 Wh/kg

Number of batteries or modules per vehicle: 1 (one) Total Battery Voltage: 350 nominal

Charger(s): On-Board X Off-board      Conductive X Inductive     

Drive Motor(s): AC Induction X DC Brush      DC Brushless     

Switched Reluctance      Other (specify)     

Number of Drive Motor(s): 2 (Two) Rated Motor Power 193 / 193 KW @ 7,000 rpm Max rpm 14,000

Drive: FWD      RWD      4WD-FT X 4WD-PT     

Regenerative Braking: No      Yes X FW      RW      AW X

Driver Controlled Regen Braking: Yes      No X Coast Regen Braking: Yes X No     

Air Conditioning: Yes X No     

Fuel-fired Heater: No      Fuel Type: Gas      Diesel      CNG      LNG     

LPG      Other (specify)      Rated Heat Power:      kW     

| Vehicle Models<br>(if coded, see<br>attachments) | Transmission<br>Type; M5, A4<br>(if applicable) | GVWR<br>kg (lbs) | Min. Curb<br>Weight kg<br>(lbs) | ETW<br>or<br>Test Weight<br>kg (lbs) | DPA / RLHP<br>or<br>Dyno Coefficient<br>a=, b=, c= |
|--|---|------------------|---------------------------------|--------------------------------------|--|
| 100D   | A1  | 2694 (5926)      | 2215 (4873)                     | 2386 (5250)                          | a=40.52, b=0.1677,<br>c= 0.01614                   |

2017 MODEL-YEAR AIR  
RESOURCES BOARD  
SUPPLEMENTAL DATA SHEET  
ZEV-PASSENGER CARS, LIGHT-DUTY TRUCKS AND MEDIUM DUTY  
VEHICLES

**100D**

Manufacturer: Tesla, Inc.

Engine Family: HTSLV00.0L2S

| Range Test Results: |       |   |  |                  |                           |                           |                            |
|---------------------|-------|---|--|------------------|---------------------------|---------------------------|----------------------------|
| Vehicle ID          | Trans | (check one)<br>____ TW<br>____ ETW<br>X | (check one)<br>____ DPA<br>____ RLHP<br>or Dyno Coefficient<br>X | City<br>Range    | System<br>AC<br>(Wh/mile) | System<br>DC<br>(Wh/mile) | Vehicle<br>DC<br>(Wh/mile) |
| DS417-172225        | n/a   | 5250                                    | 11.90  | 449.76           | 251.7                     | 221.472                   | 221.472                    |
|                     |       |   |  | Highway<br>Range | System<br>AC<br>(Wh/mile) | System<br>DC<br>(Wh/mile) | Vehicle<br>DC<br>(Wh/mile) |
|                     |       |   |  | 455.37           | 248.6                     | 218.743                   | 218.743                    |

Battery Test Results: Specific Energy: 160 \* Wh/kg

Fuel-fired Heater Test Results (emission results in grams / mile): Not applicable

| <u>NMHC</u>    | <u>CO</u>      | <u>NOx</u>     |
|----------------|----------------|----------------|
| Not applicable | Not applicable | Not applicable |